

400 Series

403D-17

Compact Industrial and Construction Power

23.6 kW / 31.6 bhp @ 2400 rpm

26.1 kW / 35.0 bhp @ 2600 rpm

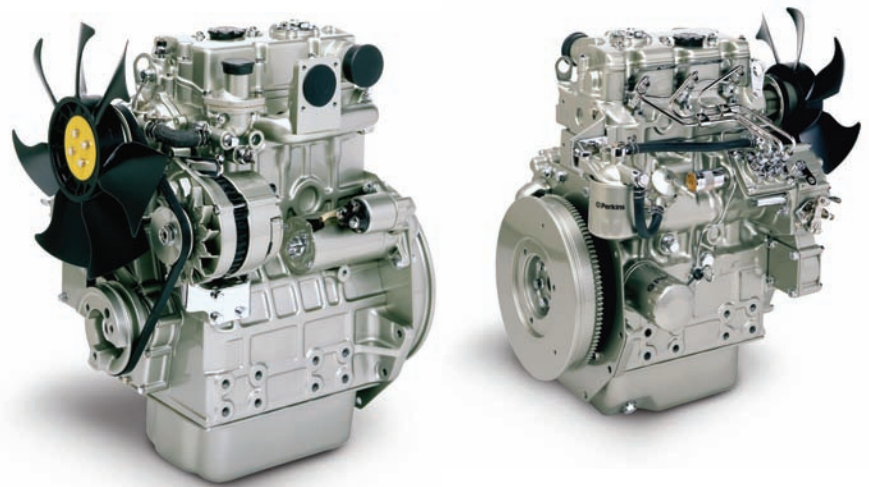

The Perkins 400D range has been developed in consultation with our marketplace. This 1.7 litre, 3 cylinder engine is a new product to the 400 Series product line-up. The 403D-17 increases a customer's choice and offers increased power with a minimal impact on package size. The 403D-17 also offers all the customer benefits they can experience from other products in the range.

The 400 Series engine family continues to set new standards in the compact engine market. Developed alongside customers to fulfil their needs in the construction, materials handling, agricultural/turf, genset and compressor markets, it is another class leading diesel range from Perkins.

Built to the most demanding standards, the 400D engines meet all the requirements of the off-highway emissions legislation for Stage IIIB, Tier 4 Interim and MLIT Step 4 (see 'Perkins Emissions Statement' on page 2). Long 500 hour service intervals, a two year standard warranty, low noise and harshness, and a wide range of options make the 400 Series range the complete solution for compact power needs.

The 403D-17 is a very quiet 1.7 litre unit that delivers improved performance and reduced operating costs in a small, efficient package ideal for a range of off-highway applications.

Ultra-compact power

- Up to 26 kW from an engine envelope of 0.16 m³.
- Coolant temperature of 112°C allows reduction in radiator size.

Clean and quiet

- Noise levels have been kept to a minimum.
- Subjective harshness has been carefully controlled making the engine sound even quieter.

Durable power

- Product design and process improvements enhance both engine reliability and durability.
- An improved governor and compliance testing delivering reliability of 6,000 hours.
- A standard 2-year warranty demonstrates our confidence in durability and reliability.

Low operating costs

- Approved for operation on biodiesel* concentrations of up to 20%.
- Oil and filter changes are 500 hours, dependent on load factor.
- Engine durability and reliability, the warranty offering, and ease of installation combine to drive down the cost of ownership.

Product support

- Through an experienced global network of distributors and dealers, fully trained engine experts deliver total service support around the clock, 365 days a year. They have a comprehensive suite of web based tools at their fingertips, covering technical information, parts identification and ordering systems, all dedicated to maximising the productivity of your engine.
- Perkins actively pursues product support excellence by insisting our distribution network invest in their territory to provide you with a consistent quality of support across the globe.
- Throughout the entire life of a Perkins engine, we provide access to genuine OE specification parts giving 100% reassurance that you receive the very best in terms of quality for lowest possible cost... wherever your Perkins powered machine is operating in the world.

Performance Data	Gross Intermittent (ISO/TR 14396)	Speed (rev/min)
Power Output (kW)	26.1	2600
Power Output (bhp)	35.0	2600
Peak Torque (Nm)	106.0	1800
Peak Torque (lbf ft)	78.1	1800

Power output for a run-in engine after 60 hours.
 *Subject to conformance with ASTM D6751 and EN14214.

400 Series - 403D-17

Compact Industrial and Construction Power

23.6 kW / 31.6 bhp @ 2400 rpm
 26.1 kW / 35.0 bhp @ 2600 rpm

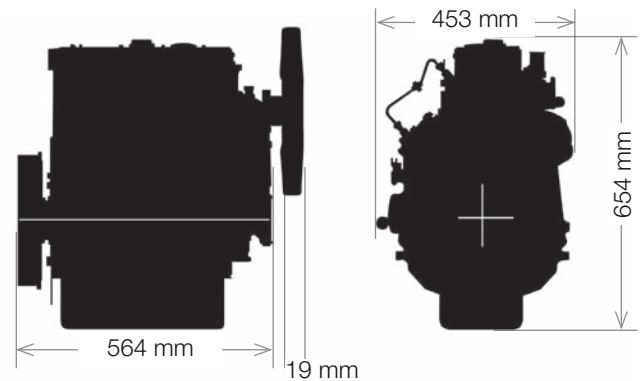

Engine specification

- Cast iron engine block
- Flywheel and flywheel housing
- CTD fuel injection pump
- Spin on fuel filter
- Glow plug starting aid
- Lub oil sump
- Spin on lub oil filter
- Inlet manifold
- Cast iron exhaust manifold – side outlet
- Coolant pump belt driven
- Choice of cooling fans
- Starter motor 12 volt and 24 volt
- Alternator 12 volt and 24 volt
- ESOS (Electric shut-off solenoid)
- Lub oil pressure switch
- Coolant temperature switch
- SAE A PTO
- Cold start to -20°C (aided)

Option groups

A selection of optional items is available to enable you to prepare a specification precisely matched to your needs.

Emissions statement

- Variable Speed: Industrial and IOPU engines: Certified against the requirements of EU Stage IIIB (Directives 97/68/EC, as last amended, and 2005/26/EC, as last amended); and US EPA Tier 4 Interim (40CFR Parts 1039. (NOTE Tier 4 Final will start in 2013 model year for 19-56 kW engines).
- Constant Speed Engines for use in Industrial, IOPU and ElectropaK applications: Certified against the requirements of EU Stage IIIA (Directives 97/68/EC, as last amended, for mobile applications); and US EPA Tier 4 Interim (40 CFR Parts 60 for stationary applications and 40CFR Part 1039 for mobile applications).

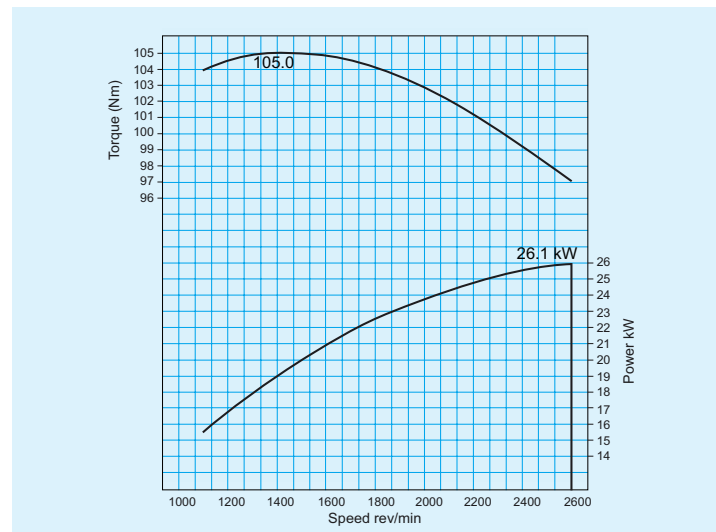

Lower speed ratings may not be read from this curve.

Engine data

Number of cylinders	3 in-line
Bore and stroke	84 x 100 mm
Displacement	1.662 litres
Aspiration	Naturally aspirated
Cycle	4 stroke
Combustion system.....	Indirect injection
Compression ratio	23:1
Rotation.....	Anti-clockwise viewed on flywheel
Cooling system.....	Liquid
Total lubrication capacity.....	6 litres
Total coolant capacity	2.5 litres
Dimensions	
Length	564 mm
Width.....	453 mm
Height.....	654 mm
Dry weight	160 kg

Final weight and dimensions will depend on completed specification.

Perkins Engines Company Limited

Peterborough PE1 5NA
 United Kingdom
 Telephone +44 (0)1733 583000
 Fax +44 (0)1733 582240
www.perkins.com

Distributed by: